

**CONSEW**<sup>®</sup>  
CONSOLIDATED SEWING MACHINE CORP.

# MODEL DLS600

High Speed Single Needle Lockstitch  
Industrial Sewing Machine

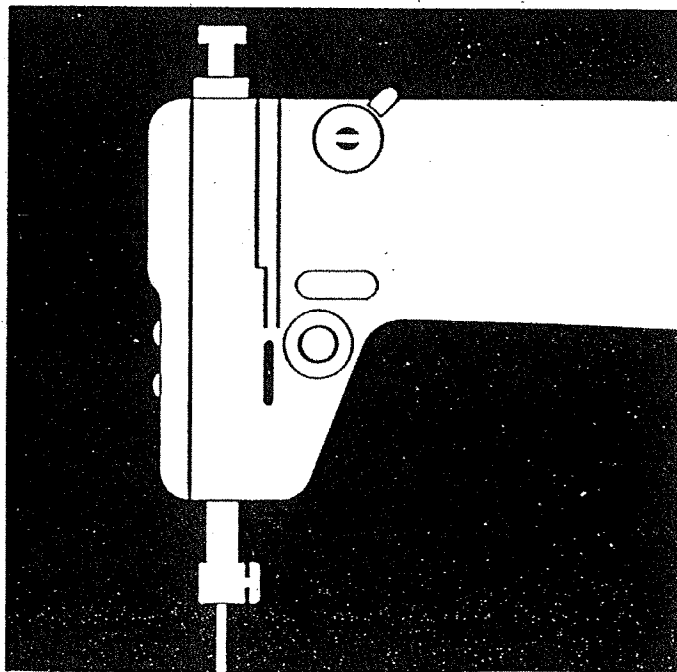

**PARTS LIST**

## CONTENTS

	PAGE
<b>1. FRAME &amp; MISCELLANEOUS COVER COMPONENTS</b>	<b>1</b>
<b>2. MAIN SHAFT &amp; UPRIGHT SHAFT &amp; NEEDLE BAR COMPONENTS</b>	<b>3</b>
<b>3. HOOK DRIVING SHAFT &amp; PRESSER BAR &amp; KNEE LIFTER COMPONENTS</b>	<b>5</b>
<b>4. FEED MECHANISM COMPONENTS (1)</b>	<b>7</b>
<b>5. FEED MECHANISM COMPONENTS (2)</b>	<b>9</b>
<b>6. OIL LUBRICATIONCOMPONENTS</b>	<b>11</b>
<b>7. OIL RESERVOIR &amp; KNEE LIFTER COMPONENTS</b>	<b>12</b>
<b>EXCLUSIVE PARTS OF SUBCLASS SEWNG MACHINES</b>	<b>13</b>
<b>8. EXCLUSIVE PARTS FOR SUBCLASS COMPONENTS</b>	<b>14</b>
<b>9. NUMERICAL INDEX OF PARTS</b>	<b>16</b>

# 1. FRAME & MISCELLANEOUS COVER COMPONENTS

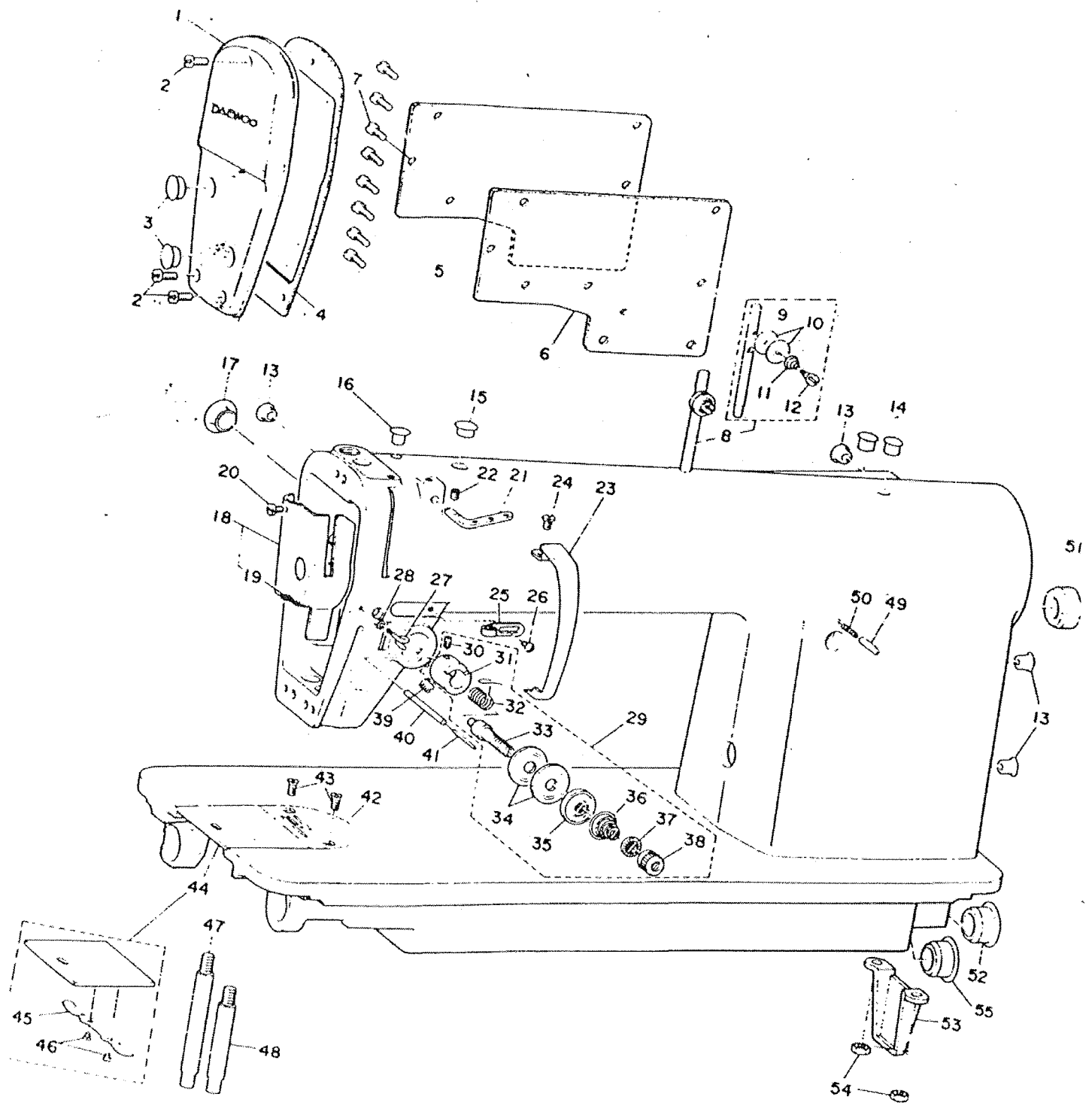

# 1. FRAME & MISCELLANEOUS COVER COMPONENTS

Ref. No.	Part No.	Description	E.C.	Amt. Req.
1	B1121-945-0A0	Face plate asm.		1
2	SS-7111120SP	Screw 11/64-40 L=10.5		3
3	B1179-552-000	Rubber plug		2
4	B1122-945-000	Gasket		1
5	B1118-945-000	Side plate		1
6	B1119-522-000	Gasret		1
7	SS-7110910-SP	Screw 11/64-40 L=8.5		8
8	B1113-155-0A0	Needle thread guide pin asm.		1
9	B1113-155-000	Needle thread guide pin		(1)
10	B3148-123-000	Tension disc		(2)
11	B3149-123-A00	Spring		(1)
12	SD-0380552-SL	Stud D=3.8 H=5.5		(1)
13	B1117-552-000	Rubber plug		4
14	B1186-552-000	Rubber plug		2
15	B1187-552-000	Rubber plug		1
16	B1117-552-000	Rubber plug		1
17	B1164-012-000	Counterweight screw hole plug		1
18	B1188-552-0A0	Arm oil shield asm.		1
19	CQ-2020000-00	Oil wick		(0.1)
20	SS-6080410-SP	Screw 11/64-40 L=5		1
21	B1128-552-000	Three-hole thread eyelet		1
22	SS-8110510-SP	Screw 11/64-40 L=5.0		1
23	B1123-552-000-A	Thread take-up lever cover		1
24	SS-7110510-SP	Screw 11/64-40 L=5.0		1
25	B1126-552-000	Frame thread guide (A)		1
26	SS-5090610-SP	Screw 9/64-40 L=3.5		1
27	B3114-761-000	Frame thread guide (B)		1
28	NS-6060350-SP	Nut 3/32-56		1
29	B3111-552-0A0	Thread tension asm.		1
30	SS-8090670-6P	Screw 9/64-40 L=5.5		(1)
31	B3111-552-B00	Thread tension post socket		(1)
32	B3128-012-000	Take-up spring		(1)
33	B3115-552-000	Thread tension post		(1)
34	B3126-012-000	Thread tension disc		(2)
35	B3132-552-000	Presser		(1)
36	B3129-012-A00	Thread tension spring		(1)
37	B3120-125-000	Thread disc rotation stopper		(1)
38	B3116-125-000	Thread tension nut		(1)
39	SS-8150710-SP	Clamp screw 15/64-28 L=7.0		1
40	B3127-127-000	Tension release auxiliary pin		1
41	B3118-552-C00	Tension release pin		1
42	B1109-012-A00	Throat plate (A)		1
43	SS-2110920-TP	Screw 11/64-40 L=8.5		2
44	B1110-012-0A0	Bed slide asm.		1
45	B1111-012-000	Spring		(1)
46	SS-6060210-SP	Screw 3/32-56 L=1.9		(2)
47	B1104-122-000	Bed screw stud (A)		1
48	B1105-122-000	Bed screw stud (B)		1
49	B1147-555-000	Feed regulator pin		1
50	B1148-555-000	Spring		1
51	B1189-415-000	Rubber plug		1
52	B1166-552-000-A	Hook shaft rubber plug		1
53	B1106-122-000	Bed support		1
54	NS-6150310-SP	Nut 15/64-28		2
55	B1166-552-000-A	Rubber plug		1

## 2. MAIN, UPRIGHT SHAFT & NEEDLE BAR COMPONENTS

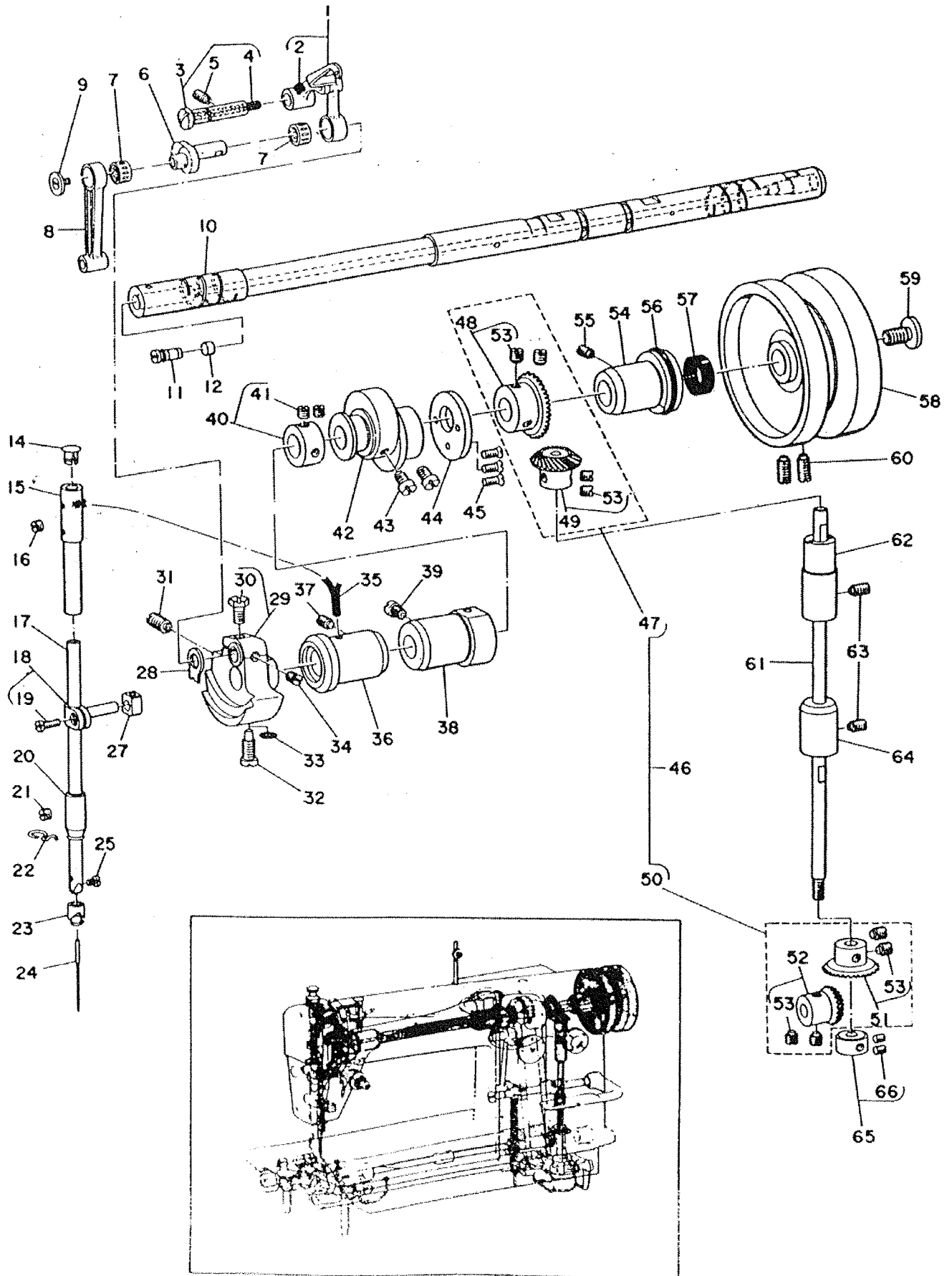

## 2. MAIN, UPRIGHT SHAFT & NEEDLE BAR COMPONENTS

Ref. No.	Part No.	Description	E.C.	Amt. Req.
1	B1901-552-0C0	Thread take-up lever asm.		1
2	CQ-2000000-00	Oil wick		(0.1)
3	B1904-552-0A0	Thread take-up crank shaft stud asm.		1
4	CQ-2020000-00	Oil wick		(0.2)
5	SS8151150-SP	Screw 15/64-28 L=10.5		1
6	B1209-552-000	Needle crank		1
7	B1905-541-B00	Needle shaft bushing		2
8	B1408-552-000	Needle bar crank rod		1
9	B1903-552-000	Thread take-up crank screw, left		1
10	B1201-555-000	Main shaft		1
11	B1213-552-0A0	Crank oil adjusting pin asm.		1
12	B1226-552-000	Oil regulating felt		1
13				
14	B1405-012-000	Rubber plug		1
15	B1402-552-000-A	Needle bar bushing, upper		1
16	SS-8150310-SP	Screw 15/64-28 L=3.4		11
17	B1401-552-A00	Needle bar (A)		1
18	B1411-552-0A0	Needle bar connection asm.		1
19	SS-6090670-TP	Clamp screw 9/64-40 L=6.0		(1)
20	B1403-155-000	Needle bar bushing, lower		1
21	SS-8150310-SP	Screw 15/64-28 L=3.4		1
22	B1419-155-000	Needle bar thread guide		1
23	B1418-541-000	Needle bar thread guide		1
24	MDB-100B1400	Needle (DBx1, #14)		1
25	SS-7080510-SP	Screw 1/8-44 L=4.5		1
27	B1414-232-000	Needle bar guide block		1
28	B1212-552-A00	Counterweight wearing plate (A)		1
29	B1206-552-0A0	Counterweight asm.		1
30	SS-9661120-CP	Clamp screw 1/4-40 L=10.5		(1)
31	SS-8681950-SP	Screw (B) 9/32-28 L=19.0		1
32	SS-7681650-TP	Screw (A) 9/32-28 L=19.0		1
33	RO-0442401-00	Rubber ring		1
34	SS-8660610-TP	Screw 1/4-40 L=6.0		1
35	CQ-2020000-00	Oil wick		0.3
36	B1202-552-B00A	Main shaft bushing, front		1
37	SS-8151150-SP	Screw 15/64-28 L=10.5		1
38	B1203-227-000	Main shaft bushing, intermediate		1
39	SS-7151120-SP	Screw 15/64-28 L=11.0		1
40	CS-147121A-SH	Main shaft thrust collar asm.		1
41	SS-8660610-TP	Screw 1/4-40 L=6.0		(2)
42	B1610-555-000	Feed drive eccentric cam		1
43	SS-666110-SP	Screw 1/4-40 L=11.0		2
44	B1611-161-000	Feed eccentric thrust washer		1
45	SS-2110930-SP	Screw 11/64-40 L=8.7		3
46	B1306-155-0C0	Gear & pinion asm.		1
47	B1306-155-0B0	Gear & pinion asm., upper		(1)
48	B1305-012-0A0	Gear asm.		(1)
49	B1306-155-0A0	Pinion asm.		(1)
50	B1307-155-0B0	Gear & pinion asm., lower		(1)
51	B1307-155-0A0	Gear asm.		(1)
52	B1308-155-0A0	Pinion asm.		(1)
53	SS-8660810-TP	Screw 1/4-40 L=8.0		(8)
54	B1204-552-B00	Main shaft bushing, rear		1
55	SS-8151150-SP	Screw 15/64-28 L=10.5		1
56	RO-2943101-00	Rubber ring		1
57	B1208-552-000-A	Oil seal ring		1
58	B1217-555-000	Hand wheel		1
59	B1233-012-000	End screw		1
60	SS-8151150-SP	Screw 15/64-28 L=15.0		2
61	B1301-552-000	Upright shaft		1
62	B1302-552-B00	Bushing, upper		1
63	SS-8151150-SP	Screw 15/64-28 L=10.5		2
64	B1303-552-B00	Bushing, lower		1
65	CS-0791010-SH	Thrust collar asm.		1
66	SS-8110520-TP	Screw 11/64-40 L=4.5		(2)

### 3. HOOK DRIVING SHAFT, PRESSER BAR & KNEE LIFTER COMPONENTS

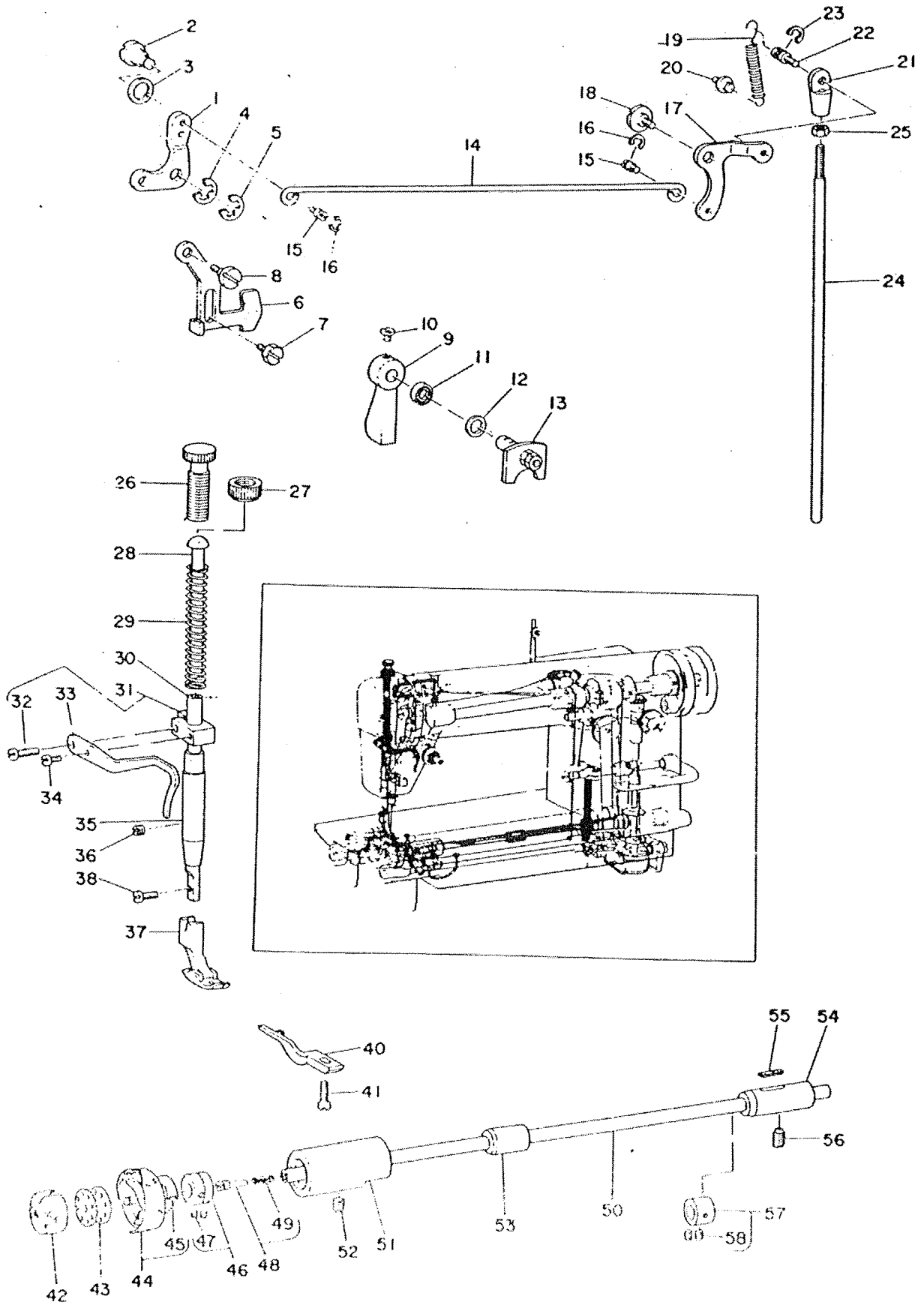

### 3. HOOK DRIVING SHAFT, PRESSER BAR & KNEE LIFTER COMPONENTS

Ref. No.	Part. No.	Description	E.C.	An Re
1	B1516-552-000	Lifting lever link		1
2	B1517-552-000	Shaft		1
3	B3431-581-000	Gasket		1
4	RE-0600000-K0	Snap ring		1
5	B1523-226-000	Snap ring (B)		1
6	B1515-552-000	Lifting lever		1
7	SD-0630275-SP	Hinge screw (A) D=6.35 H=2.7		1
8	SD-0630301-SP	Hinge screw (B) D=6.35 H=3.0		1
9	B1520-552-000	Hand lifter lever		1
10	SS-7120910-SP	Screw 3/16-28 L=9.0		1
11	B1522-552-00	Oil seal		1
12	WP-0740516-SP	Washer 7.4 x 11.2 x 0.5		1
13	B1518-522-0A0	Hand lifter cam asm.		1
14	B3412-522-000	Lifting lever connecting rod		1
15	B3416-552-000	Hinge screw		2
16	RE-0500000-K0	Spring		2
17	B3414-552-000	Lifting lever link arm		1
18	SD-0720331-SP	Hinge screw D=7.24 H=3.3		1
19	B3417-552-000	Spring		1
20	B3415-227-000	Suspension screw		1
21	B3416-012-000	Swivel		1
22	B3418-552-000	Screw		1
23	RE-0500000-K0	Snapring		1
24	B3415-552-000	Connecting rod, vertical		1
25	NS-6620310-SP	Nut 3/16-32		1
26	B1509-227-000	Presser spring regulator		1
27	NS-2820850-SA	Nut 1/2-28		1
28	B1510-227-000	Presser guide bar		1
29	B1505-227-000-A	Presser spring		1
30	B1501-127-000	Presser bar		1
31	B1507-552-000	Presser bar guide bracket asm.		1
32	SS-7111410-SP	Clamp screw 11/64-40 L=14.0		(1)
33	B1521-552-000	Presser bar clamp thread guide		1
34	SS-6090650-SP	Screw 9/64-40 L=6.0		1
35	B1502-541-000	Presser bar bushing, lower		1
36	SS-8150310-SP	Screw 15/64-28 L=3.4		1
37	B1524-012-0A0	Hinged presser foot asm.		1
38	SS-7091110-SP	Screw 9/64-40 L=10.5		1
40	B-1835-012-000	Bobbin case holder positioning finger		1
41	SS-6111010-SP	Screw 11/64-40 L=9.5		1
42	B1837-012-0A0	Bobbin case asm.		1
43	B9117-012-000	Bobbin		1
44	B1830-127-0A0	Lubricating hook asm.		1
45	SS-6110560-TP	Screw		(2)
46	CS-079106A-SH	Thrust collar asm.		1
47	SS-8110410-TP	Screw 11/64-40 L=3.5		(2)
48	B1808-552-0A0	Hook driving shaft front screw asm.		1
49	B1810-552-000	Oil wick asm.	D.7/75	-
	B1810-552-000	Oil wick	A.7/75	(1)
50	B1801-412-000	Hook driving shaft		1
51	B1802-412-0A0	Bushing, front asm.		1
52	SS-8151150-SP	Screw 15/64-28 L=10.5		1
53	B1803-552-000	Bushing, intermediate		1
54	B1806-038-000	Bushing, rear		1
55	B1906-038-000	Oil felt		1
56	SS-8151550-SP	Screw 15/64-28 L=15.0		1
57	CS-0791010-SH	Hook driving shaft thrust collar (B) asm.		1
58	SS-8110520-TP	Screw 11/64-40 L=4.5		(2)



# 4. FEED MECHANISM COMPONENTS (1)

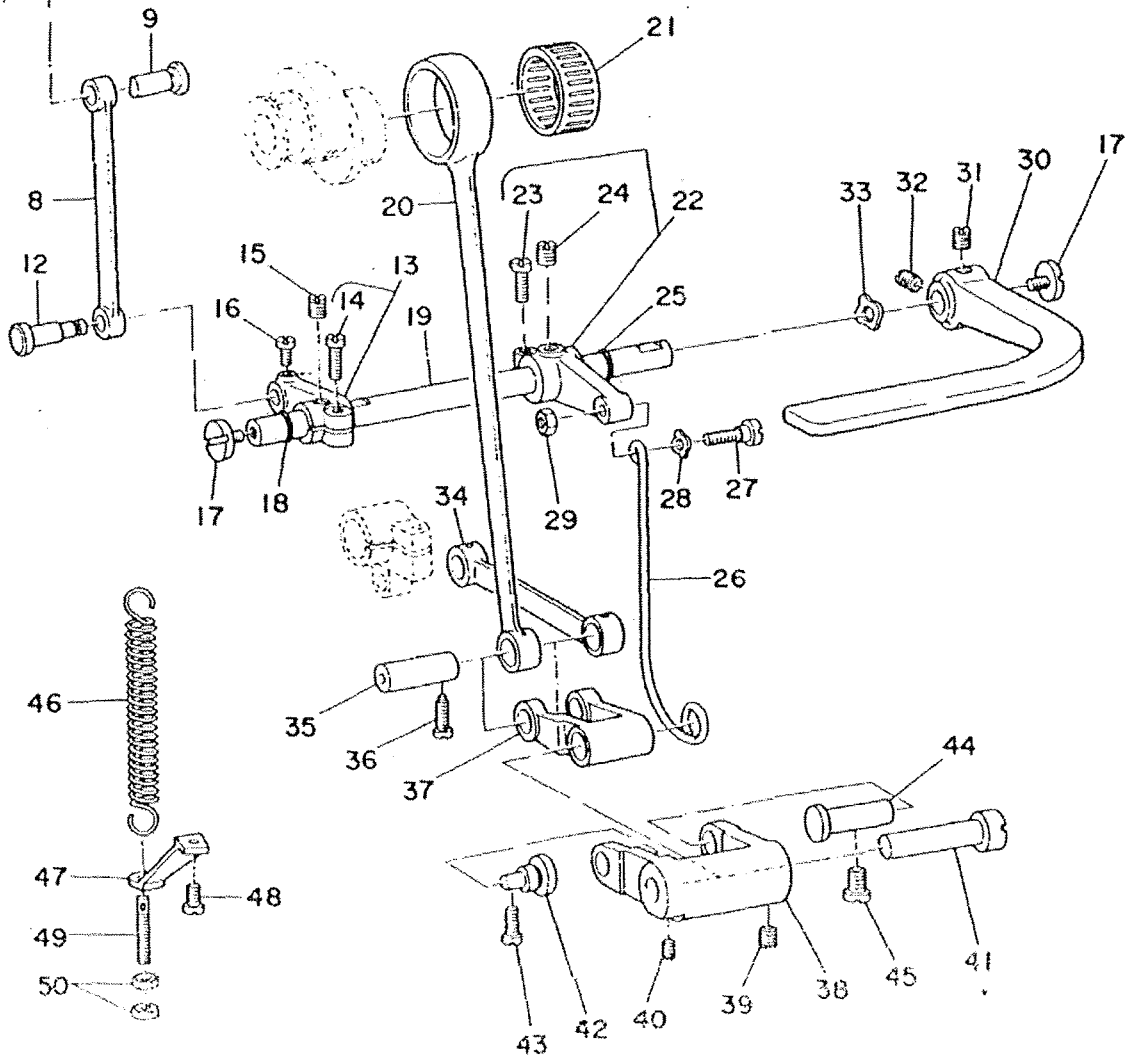
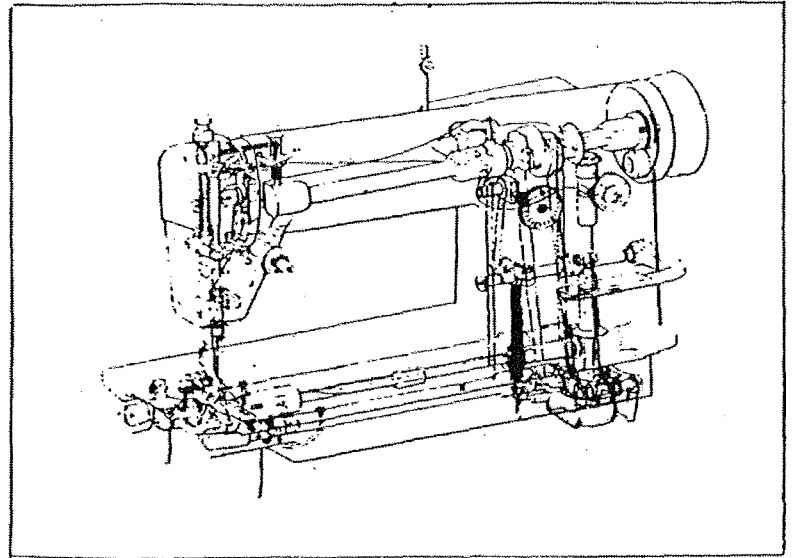
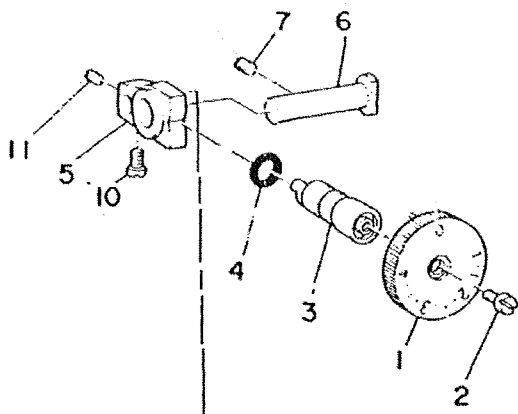

## 4. FEED MECHANISM COMPONENTS (1)

Ref. No.	Part. No.	Description	E.C.	Amt. R	Req.
1	B1623-555-0A0-A	Stitch dial asm.			1
2	SS-6121050-SP	... Screw 3/16-28 L=9.5			1
3	B1634-555-000-A	Feed regulating screw	D.6/67		1
3-1	B1634-555-000-B	Feed regulating screw	A.6/67		1
4	RO-0742401-00	... Rubber ring			1
5	B1620-161-000	Feed regulator			1
6	B1622-555-000	... Hinge pin			1
7	SS-8151230-SP	... Screw 15/64-28 L=12.0			1
8	B1625-555-000	Feed regulator connecting rod			1
9	B1626-555-000	... Pin			1
10	SS-7110720-SP	... Screw (A) 11/64-40 L=7.0			1
11	SS-8110510-SP	... Screw (B) 11/64-40 L=5.0			1
12	B1628-555-000	Tension spring suspension stud			1
13	B1627-555-0A0	Tension spring suspension crank asm.			1
14	SS-6121210-SP	... Clamp screw 3/16-28 L=12.0			(1)
15	SS-8150710-SP	... Screw 15/64-28 L=7.0			1
16	SS-7110910-SP	Screw, 11/64-40 L=8.5			1
17	SS-7620750-SP	End screw 3/16-32 L=6.5			2
18	RO-0611801-00	Rubber ring, small			1
19	B1621-555-000	Reverse feed control lever shaft			1
20	B1612-161-000	Feed rocker shaft connecting rod			1
21	B1636-581-B00	... Needle bearing			1
22	B1629-555-0A0	Control lever crank, rear asm.			1
23	SS-6121210-SP	... Clamp screw 3/16-28 L=12.0			(1)
24	SS-8150710-SP	... Screw 15/64-28 L=7.0			1
25	RO-0691801-00	Rubber ring, large			1
26	B1630-555-000	Feed driving rocker arm connecting rod			1
27	SD-05000401-KP	... Hinge screw D=5.0 H=4.0			1
28	WZ-0541510-KP	... Washer 5.4 x 9.0 x 0.3			1
29	NS-6120310-SP	... Nut 3/16-28			1
30	B1624-555-000	Reverse feed control lever			1
31	SS-8660970-TP	... Screw (A) 1/4-40 L=8.5			1
32	SS-8660810-TP	... Screw (b) 1/4-40 L=8.0			1
33	WZ-1052010-KP	... Waved washer 10.5 x 14.5 x 0.3			1
34	B1613-555-000	Connecting rod			1
35	B1633-555-000	Feed rocker shaft connecting pin			1
36	SS-7111260-SP	... Screw 11/64-40 L=12.0			1
37	B1614-555-000	Feed driving rocker arm			1
38	B1617-555-000	Feed driving rocker			1
39	SS-8150710-SP	... Screw (A) 15/64-28 L=7.0			1
40	SS-8620610-SP	... Screw (B) 3/16-32 L=6.0			1
41	B1615-555-000	... Hinge pin			1
42	B1619-555-000	... Hinge stud			1
43	SS-7111120-SP	... Screw 11/64-40 L=10.5			1
44	B1618-161-000	Feed driving rocker arm hinge pin			1
45	SS-7151120-SP	... Screw 15/64-28 L=11.0			1
46	B1646-555-000	Tension spring			1
47	B1632-555-000	... Suspension bracket			1
48	SS-7111120-SP	... Screw 11/64-40 L=10.5			1
49	B1649-161-000	... Adjusting screw			1
50	NS-6110420-SP	... Nut 11/64-40			2

# 5. FEED MECHANISM COMPONENTS (2)

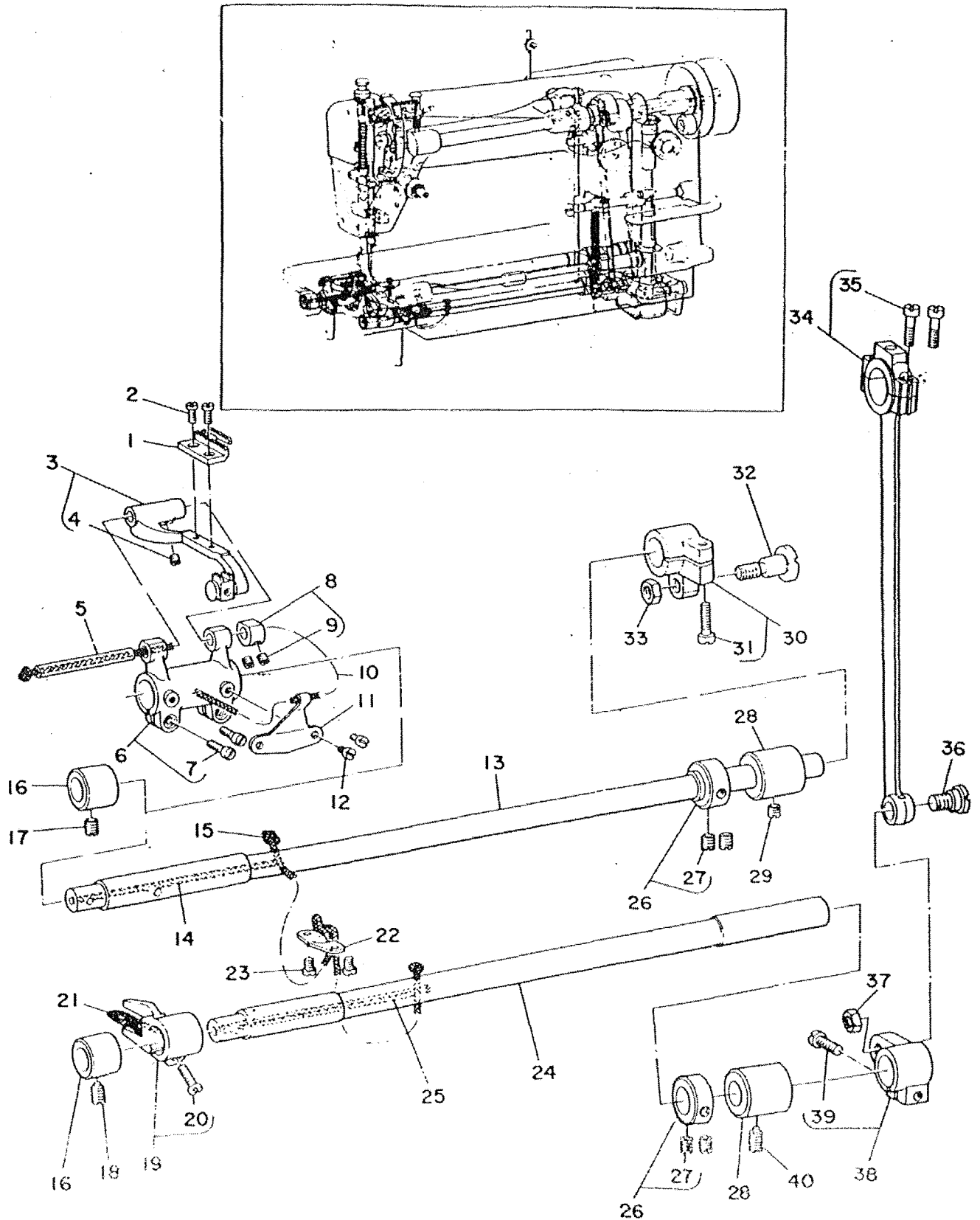

## 5. FEED MECHANISM COMPONENTS (2)

Ref. No.	Part No.	Description	E.C.	Amt. Req.
1	B1613-012-A00	Feed dog (A)		1
2	SS-4080620-TP	Screw 1/8-44 L=6.4		2
3	B1602-155-0B0	Feed bar asm.		1
4	SS-8620610-TP	Shaft clamp screw 3/16-32 L=6.0		(1)
5	B1604-012-000	Shaft		1
6	B1603-155-0A0	Feed rocker asm.		1
7	SS-7111310-TP	Clamp screw 11/64-40 L=12.8		(2)
8	CS-0640860-SH	Thrust collar asm.		1
9	SS-8110510-SP	Screw 11/64-40 L=5.0		(2)
10	CQ-3030000-00	Oil wick		0.2
11	B1609-155-000	Holder		1
12	SS-6080410-SP	Screw 1/8-44 L=4.0		2
13	B1601-552-000	Feed rocker shaft		1
14	CQ-3030000-00	Oil wick (A)		0.3
15	CQ-3030000-00	Oil wick (B)		0.5
16	B1604-155-000	Feed rocker shaft bushing, front		2
17	SS-8150710-SP	Screw 15/64-28 L=7.0		1
18	SS-8151550-SP	Screw 15/64-28 L=15.0		1
19	B1704-155-0A0	Feed rocker shaft crank asm.		1
20	SS-7111120-SP	Clamp screw 11/64-40 L=10.5		(1)
21	CQ-2020000-00	Oil wick		0.1
22	B1635-552-000	Holder		1
23	SS-7110540-SP	Screw 11/64-40 L=5.0		2
24	B1701-555-000	Feed driving shaft		1
25	CQ-3030000-00	Oil wick (A)		0.3
26	CS-147121A-SH	Thrust collar asm.		2
27	SS-8660610-TP	Screw 1/4-40 L=6.0		(4)
28	B1702-155-000	Bushing, rear		2
29	SS-8150410-SP	Screw 15/64-28 L=4.0		1
30	B1608-161-0A0	Feed rocker shaft crank, rear asm.		1
31	SS-6121610-TP	Clamp screw 3/16-28 L=15.5		(1)
32	SD-1020701-SP	Hinge screw D=10.2 H=7.0		1
33	NS-6680410-SP	Nut 9/32-28		1
34	B1708-555-0A0	Feed driving shaft connecting rod asm.		1
35	SS-6121610-SP	Clamp screw 3/16-28 L=15.5		(2)
36	SD-1020701-SP	Hinge screw D=10.2 H=7.0		1
37	NS-6680410-SP	Nut 9/32-28		1
38	B1703-155-0A0	Feed driving shaft crank, rear asm.		1
39	SS-6121610-TP	Clamp screw 3/16-28 L=15.5		(1)
40	SS-8150710-SP	Screw, 15/64-28 L=7.0		1

# LUBRICATION SYSTEM COMPONENTS

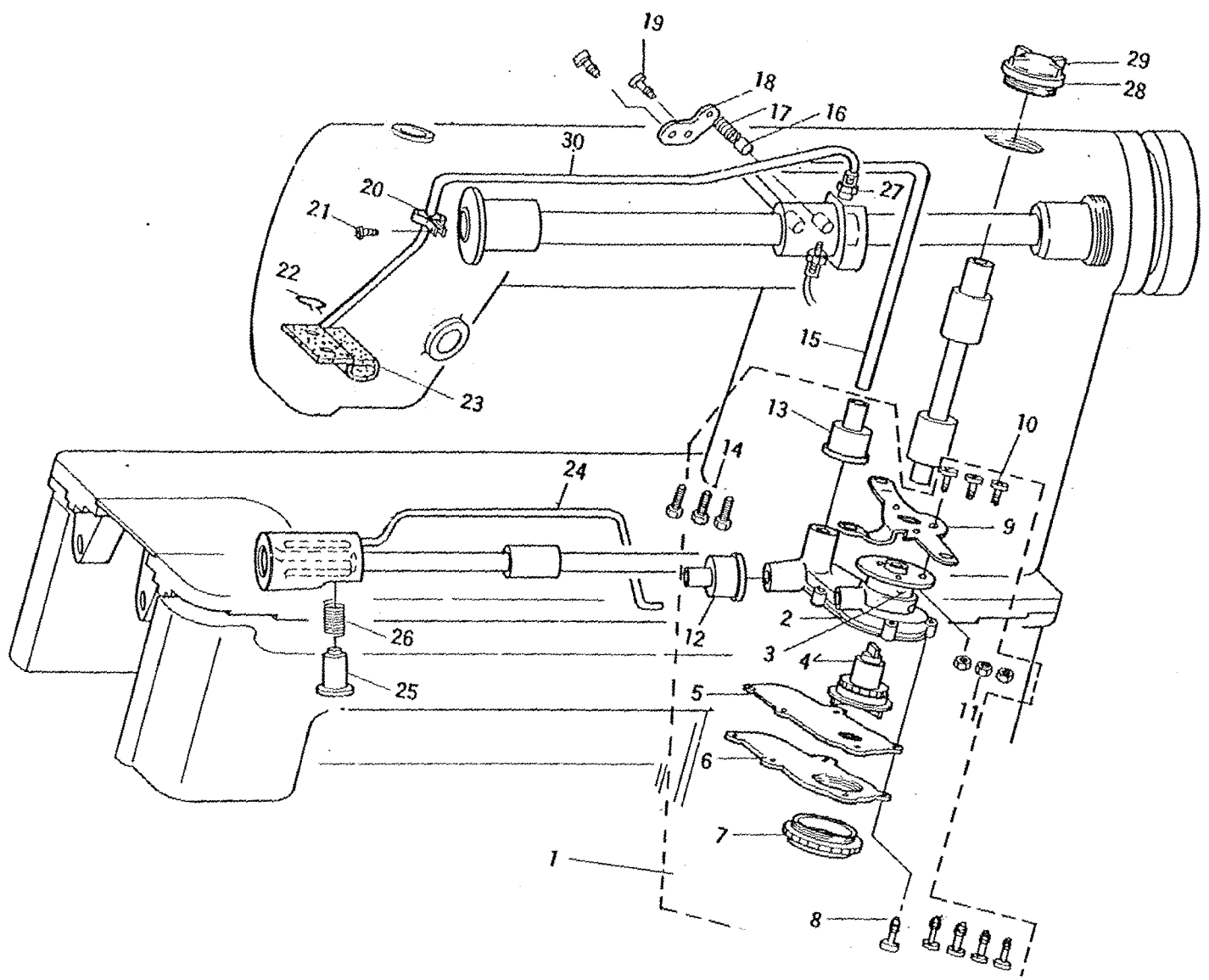

# 6. OIL LUBRICATION SYSTEM COMPONENTS

No.	Part No.	Description	Amt. Req.
1	B3501-557-0A0	Oil pump asm.	1
2	B3501-557-000	Oil pump	(1)
3	B3512-557-000	Impeller bush	(1)
4	B3505-557-000	Impeller	(1)
5	B3502-557-000	Cover	(1)
6	B3503-557-000	Screen holder	(1)
7	B3504-557-000	Screen	(1)
8	SK-3030101-SE	... Screw M3 x P1.06	(5)
9	B3506-557-000	Bracket	(1)
10	SM-7030101-SE	... Screw M3 x P0.5	(3)
11	NM-6032400-CR	... Nut M3 x P0.5	(3)
12	B3508-557-000	Oil tube joint	(1)
13	B3507-557-000	Oil tube joint	(1)
14	SS-4120900-SP	... Screw 3/16" n=28 L=9.0	(3)
15	B3509-557-000	Main shaft oil tube	1
16	B3534-155-000	Pump plunger	1
17	B1214-038-000	Spring	1
18	B3527-552-000	Plunger thrust plate	1
19	SS-7110910-SP	... Screw 11/64" n=40 L=8.5	2
20	B3536-122-000	Return tube pipe	1
21	SS-7110710-SP	... Screw 11/64" n=40 L=7.0	1
22	B3529-225-000	Presser	1
23	B3526-552-0A0	Felt asm	1
24	B3510-557-000	Hook oil tube	1
25	B3514-412-000	Oil adjusting screw	1
26	B2616-372-000	Spring	1
27	SQ-1110402-MZ	Nipple	1
28	RO-0192402-00	Oil ring	1
29	B3511-557-000	Oil window	1
30	BP-3030000-00	Oil tube	1

## 7. OIL RESERVOIR & KNEE LIFTER COMPONENTS

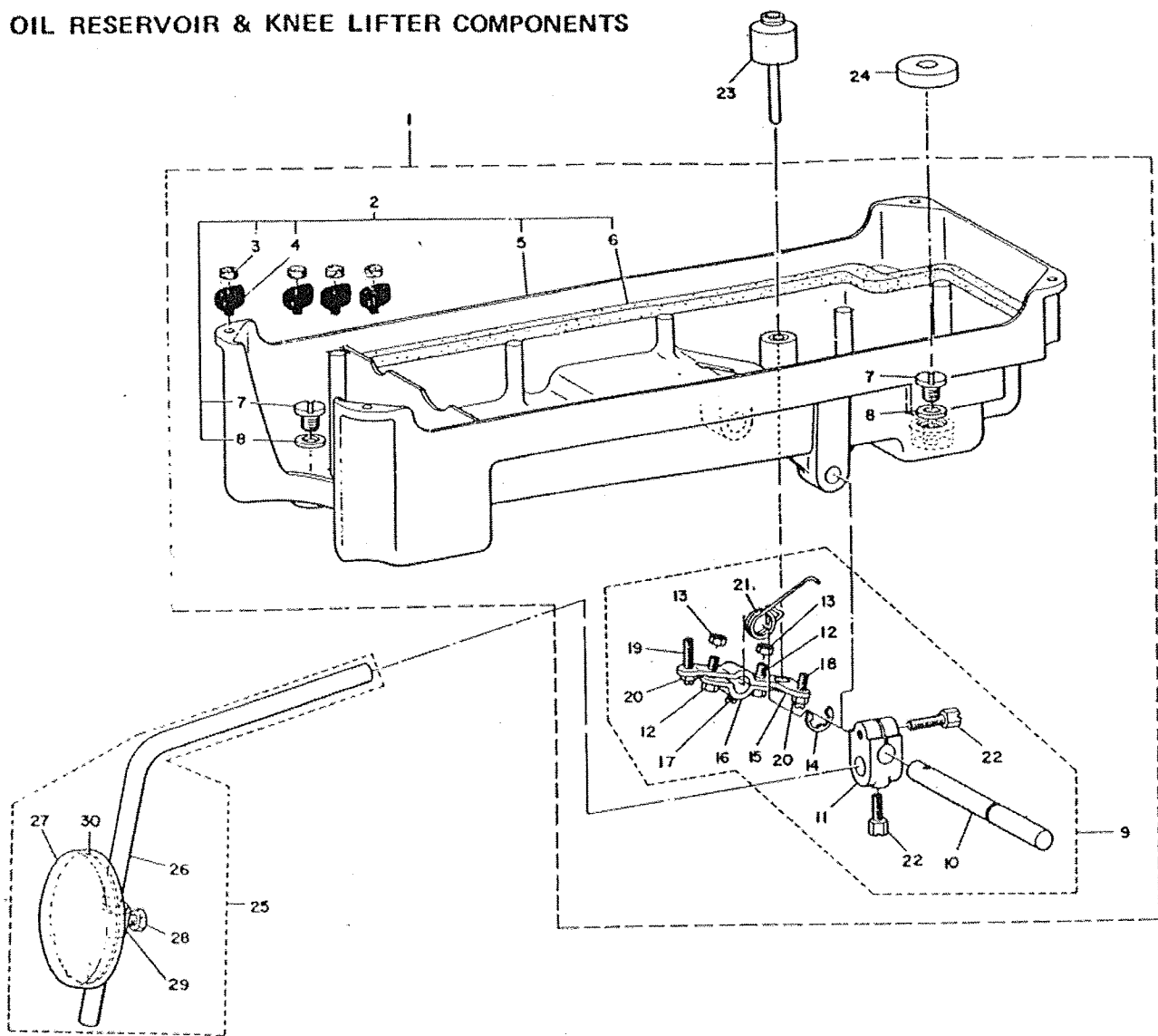

Ref. No.	Part No.	Description	E.C.	Amt. Req.
1	B8217-552-0C0	Oil reservoir asm.		1
2	B8217-552-0A0	Oil reservoir asm.		(1)
3	B8227-125-000	Felt pad		(4)
4	B8226-125-000	Rubber pad		(4)
5	B8217-552-000	Oil reservoir		(1)
6	B8281-552-000	Gasket		(1)
7	SS-6741010-SP	Oil drain cap screw 3/8-28 L=10.0		(2)
8	B8219-125-000	Gasket		(2)
9	B3420-552-0A0	Knee press rod asm.		(1)
10	B3420-552-000	Knee press rod		(1)
11	B3427-122-000	Bearing bracket		(1)
12	SS-9151540-SR	Rotating lever clamp screw 15/64-28 L=15.0		(2)
13	NS-6150430-SR	Nut 15/64-28		(2)
14	B3426-552-000	Thrust ring		(1)
15	B3425-552-000	Lifting (B)		(1)
16	B3424-552-000	Lifting (A)		(1)
17	SS-9151220-SR	Screw 15/64-28 L=12.0		(1)
18	SS-8152080-SR	Positioning screw (B) 15/64-28 L=19.5		(1)
19	SS-8153010-SR	Positioning screw (A) 15/64-28 L=30.0		(1)
20	NS-6150430-SR	Nut 15/64-28		(2)
21	B3429-552-000	Spring		(1)
22	SS-9182010-SN	Clamp screw 9/32-20 L=20.0		(2)
23	B3421-552-000	Knee press lifter rod asm.		1
24	B8228-125-000	Oil reservoir magnet		1
25	B3419-122-0A0	Knee lifter plate rod asm.		1
26	B3419-122-000	Knee lifter plate rod		(1)
27	B3431-552-000	Knee press plate cover		(1)
28	SM-9061003-SE	Stopper screw M6 L=10.0		(1)
29	B3432-552-000	Knee press plate stopper		(1)
30	B3430-552-000	Knee press plate		(1)

# EXCLUSIVE PARTS LIST OF SUBCLASS SEWING MACHINES

	Description	Standard	For heavy weight materials
1	Throat plate	B-1109-012-A00	B1109-555-HOB
2	Needle thread guide pin asm.	B1113-155-0A0	B1114-012-000
3	Frame thread guide (A)	B1126-552-000	B1126-553-000
4	Counterweight asm.	B1206-552-0A0	B1206-553-0A0
5	Needle bar crank	B1209-552-000	B1209-553-000
6	Needle bar	B1401-552-A00	B1401-552-i00
7	Needle bar bushing, lower	B1403-155-000	B1403-553-000
8	Needle bar thread guide	B1418-541-000	-
9	Needle bar thread guide	B1419-155-000	B1419-553-000
10	Presser spring	B1505-227-000-A	B1505-552-000-A
11	Hand lifter cam asm.	B1518-552-0A0	*
12	Hinged presser foot asm.	B1524-012-0A0	B1511-543-BA0
13	Feed dog	B1613-012-A00	B1613-555-H00
14	Stitch dial asm.	B1623-555-0A0-A	B1623-555-HA0-A
15	Lubricating hook asm.	B1830-127-0A0	B1830-555-HA0
16	Bobbin case holder	B1835-012-000	B1835-555-H00
17	Thread tension post socket	B3111-552-B00	*
18	Thread tension spring	B3129-012-A00	B3114-232-000
19	Take-up spring	B3128-012-000	*
20	Bobbin	B9117-012-000	*
21	Needle	MDB-100B1400	MDB-100B2200
22	Arm oil shield screw	SS-6080410-SP	SS-6080320-SP
23	Lower shaft front screw asm.	B1808-552-0A0	B1808-227-HA0
24	Feed drive eccentric cam	B1610-555-000	B1610-555-H00

Note: Parts marked with \* are same as standard parts

- . . . . . Parts to be removed

## 8. EXCLUSIVE PARTS SUBCLASS COMPONENTS

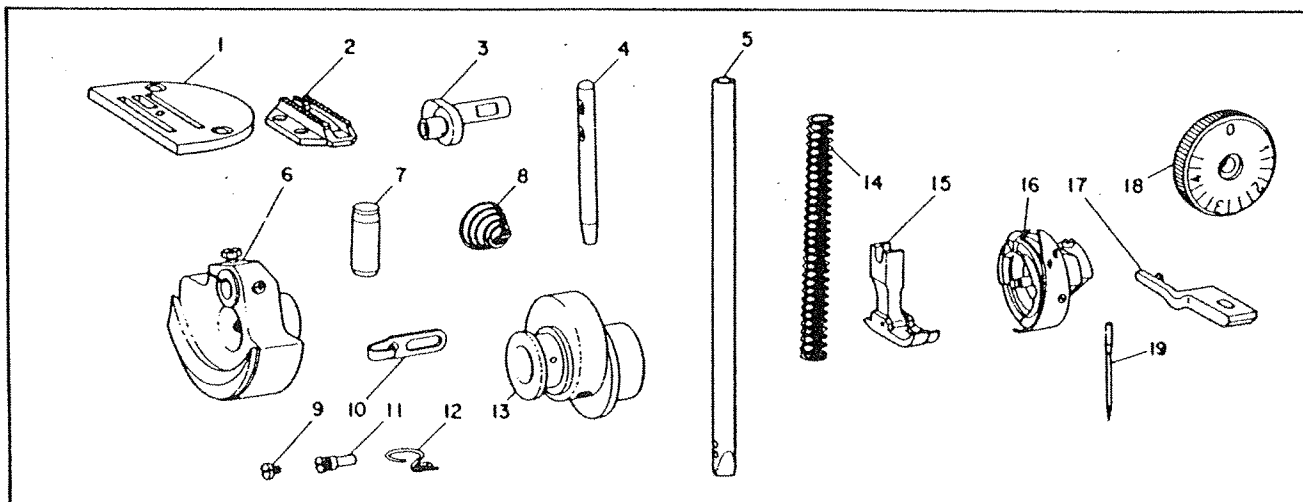

(FOR HEAVY WEIGHT MATERIALS)



1	B1109-555-H0B	Throat plate (H)	1
2	B1613-555-H00	Feed dog (H)	1
3	B1209-553-000	Needle bar crank	1
4	B1114-012-000	Needle thread guide pin	1
5	B1401-552-000	Needle bar	1
6	B1206-553-0A0	Counterweight asm.	1
7	B1403-553-000	Needle bar bushing, lower	1
8	B3114-232-000	Thread tension spring	1
9	SS-6080320-SP	Arm oil shield screw 1/8-44 L=2.5	1
10	B1126-553-000	Frame thread guide (A)	1
11	B1808-227-HA0	Hook driving shaft front screw asm.	1
12	B1419-553-000	Needle bar thread guide	1
13	B1610-555-H00	Feed drive eccentric cam	1
14	B1505-552-000-A	Presser spring	1
15	B1511-543-BA0	Hinged presser foot asm.	1
16	B1830-555-HA0	Lubricating hook asm.	1
17	B1835-555-H00	Bobbin case holder	1
18	B1623-555-HA0-A	Stitch dial asm.	1
19	MDB-100B2200	Needle DBx1 #2?	1

## 9. NUMERICAL INDEX OF PARTS

Parts. No.	Page	Ref. No.	Parts. No.	Page	Ref. No.	Parts. No.	Page	Ref. No.
B1104-122-000	01	47	B1510-227-000	03	29	B3111-552-0A0	01	29
B1105-122-000	01	48	B1511-543-BA0	08	15	B3111-552-B00	01	31
B1106-122-000	01	53	B1515-552-000	03	6	B3114-232-000	08	8
B1109-012-A00	01	42	B1516-552-000	03	1	B3114-761-000	01	27
B1109-555-H0B	08	1	B1517-552-000	03	2	B3115-552-000	01	33
B1110-012-0A0	01	44	B1518-522-0A0	03	13	B3116-125-000	01	38
B1111-012-000	01	45	B1520-552-000	03	9	B3118-552-C00	01	41
B1113-155-000	01	9	B1521-552-000	03	33	B3120-125-000	01	37
B1113-155-0A0	01	8	B1522-552-00	03	11	B3126-012-000	01	34
B1114-012-000	08	4	B1523-226-000	03	5	B3127-127-000	01	40
B1117-552-000	01	16	B1524-012-0A0	03	37	B3128-012-000	01	32
	01	13	B1601-552-000	05	13	B3129-012-A00	01	36
B1118-945-000	01	5	B1602-155-0B0	05	3	B3132-552-000	01	35
B1119-522-000	01	6	B1603-155-0A0	05	6	B3148-123-000	01	10
B1121-945-0A0	01	1	B1604-012-000	05	5	B3149-123-A00	01	11
B1122-945-000	01	4	B1604-155-000	05	16	B3412-522-000	03	14
B1123-552-000-A	01	23	B1608-161-0A0	05	30	B3414-552-000	03	17
B1126-552-000	01	25	B1609-155-000	05	11	B3415-227-000	03	20
B1126-553-000	08	10	B1610-555-000	02	42	B3415-552-000	03	24
B1128-552-000	01	21	B1610-555-H00	08	13	B3416-012-000	03	21
B1147-555-000	01	49	B1611-161-000	02	44	B3416-552-000	03	15
B1148-555-000	01	50	B1612-161-000	04	20	B3417-552-000	03	19
B1164-012-000	01	17	B1613-012-A00	05	1	B3418-552-000	03	22
B1166-552-000-A	01	52	B1613-555-000	04	34	B3419-122-000	07	26
	01	55	B1613-555-H00	08	2	B3419-122-0A0	07	25
B1179-552-000	01	3	B1614-555-000	04	37	B3420-552-000	07	10
B1186-552-000	01	14	B1615-555-000	04	41	B3420-552-0A0	07	9
B1187-552-000	01	15	B1617-555-000	04	38	B3421-552-000	07	23
B1188-552-0A0	01	18	B1618-161-000	04	44	B3426-552-000	07	14
B1189-415-000	01	51	B1619-555-000	04	42	B3427-122-000	07	11
B1201-555-000	02	10	B1620-161-000	04	5	B3429-552-000	07	21
B1202-552-B00-A	02	36	B1621-555-000	04	19	B3430-552-000	07	30
B1203-227-000	02	38	B1622-555-000	04	6	B3431-552-000	07	27
B1204-552-B00	02	54	B1623-555-0A0-A	04	1	B3431-581-000	03	3
B1206-552-0A0	02	29	B1623-555-HA0-A	08	18	B3432-552-000	07	29
B1206-553-0A0	08	6	B1624-555-000	04	30	B3501-557-000	06	2
B1208-552-000-A	02	57	B1625-555-000	04	8	B3501-557-0A0	06	1
B1209-552-000	02	6	B1626-555-000	04	9	B3502-557-000	06	5
B1209-553-000	08	3	B1627-555-0A0	04	13	B3503-557-000	06	6
B1212-552-A00	02	28	B1628-555-000	04	12	B3504-557-000	06	7
B1213-552-0A0	02	11	B1629-555-0A0	04	22	B3505-557-000	06	4
B1214-038-000	06	17	B1630-555-000	04	26	B3506-557-000	06	9
B1217-555-000	02	58	B1632-555-000	04	47	B3507-557-000	06	13
B1226-552-000	02	12	B1633-555-000	04	35	B3508-557-000	06	12
B1233-012-000	02	59	B1634-555-000-A	04	3	B3509-557-000	06	15
B1301-552-000	02	61	B1634-555-000-B	04	3-1	B3510-557-000	06	24
B1302-552-B00	02	62	B1635-552-000	05	22	B3511-557-000	06	29
B1303-552-B00	02	64	B1636-581-B00	04	21	B3512-557-000	06	3
B1305-012-0A0	02	48	B1646-555-000	04	46	B3514-412-000	06	25
B1306-155-0A0	02	49	B1649-161-000	04	49	B3524-552-000	06	18
B1306-155-0B0	02	47	B1701-555-000	05	24	B3526-552-0A0	06	23
B1306-155-0C0	02	46	B1702-155-000	05	28	B3529-226-000	06	22
B1307-155-0A0	02	51	B1703-155-0A0	05	38	B3534-155-000	06	16
B1307-155-0B0	02	50	B1704-155-0A0	05	19	B3536-122-000	06	20
B1308-155-0A0	02	52	B1708-555-0A0	05	34	B8217-552-000	07	5
B1401-552-A00	02	17	B1801-412-000	03	50	B8217-552-0A0	07	2
B1401-552-I00	08	5	B1802-412-0A0	03	51	B8217-552-0C0	07	1
B1402-552-000-A	02	15	B1803-552-000	03	53	B8219-125-000	07	8
B1403-155-000	02	20	B1806-038-000	03	54	B8226-125-000	07	4
B1403-553-000	08	7	B1808-227-HA0	08	11	B8227-125-000	07	3
B1405-012-000	02	14	B1808-552-0A0	03	48	B8228-125-000	07	24
B1408-552-000	02	8	B1810-552-000	03	49	B8281-552-000	07	6
B1411-552-0A0	02	18	B1830-127-000	03	44	B9117-012-000	03	43
B1414-232-000	02	27	B1830-555-HA0	08	16	CP-2030000-00	06	30
B1418-541-000	02	23	B1835-012-000	03	40	CQ-2000000-00	02	2
B1419-155-000	02	22	B1835-555-H00	08	17	CQ-2020000-00	01	19
B1419-553-000	08	12	B1837-012-0A0	03	42		02	35
B1501-127-000	03	30	B1901-552-0C0	02	1		02	4
B1502-541-000	03	35	B1903-552-000	02	9		05	21
B1505-227-000-A	03	29	B1904-552-000	02	3	CO-2030000-00	05	25
B1505-552-000-A	08	14	B1905-541-B00	02	7		05	15
B1507-552-000	03	31	B1906-038-000	03	55		05	14
B1509-227-000	03	26	B2616-370-000	06	26		05	18

Parts. No.	Page	Ref. No.	Parts. No.	Page	Ref. No.	Parts. No.	Page	Ref. No.
CS-0640860-SH	05	8	SS-4120900-SP	06	14	SS-8110510-SF	04	11
CS-0791010-SH	02	65	SS-5090610-SP	01	26		05	9
	03	57	SS-6060210-SP	01	46	SS-8110520-TP	02	66
CS-079106A-SH	03	46	SS-6080320-SP	08	9		03	58
CS-147121A-SH	02	40	SS-6080410-SP	01	20	SS-8150310-SP	02	16
	05	26		05	12		02	21
MDB-100B1400	02	24	SS-6090650-SP	03	34		03	36
MDB-100B2200	08	19	SS-6090670-TP	02	19	SS-8150410-SF	05	29
NM-6032400-CR	06	11	SS-6110560-TP	03	45	SS-8150710-SF	01	39
NS-2820850-SA	03	27	SS-6111010-SP	03	41		04	24
NS-6060350-SP	01	28	SS-6121050-SP	04	2		04	15
NS-6110420-SP	04	50	SS-6121210-SP	04	14		04	39
NS-6120310-SP	04	29		04	23		05	40
NS-6150310-SP	01	54	SS-6121610-SP	05	35		05	17
NS-6150430-SR	07	13		05	39	SS-8151150-SF	02	55
	07	20		05	31		02	60
NS-6620310-SP	03	25	SS-666110-SP	02	43		02	37
NS-6680410-SP	05	33	SS-6741010-SP	07	7		02	63
	05	37	SS-7080510-SP	02	25		02	5
RO-0192402-00	06	28	SS-7091110-SP	03	38	SS-8151230-SF	03	52
RO-0442401-00	02	33	SS-7110510-SP	01	24	SS-8151550-SF	04	7
RO-0611801-00	04	18	SS-7110540-SP	05	23		03	56
RO-0691801-00	04	25	SS-7110710-SP	06	21		05	18
RO-0742401-00	04	4	SS-7110720-SP	04	10	SS-8152080-SR	07	18
RO-2943101-00	02	56	SS-7110910-SP	01	7	SS-8153010-SR	07	19
RE-0500000-K0	03	23		04	16	SS-8620610-SF	04	40
	03	16		06	19	SS-8620610-TP	05	4
RE-0600000-K0	03	4	SS-7111120-SP	01	2	SS-8660610-TF	02	34
SD-0380552-SL	01	12		04	43		02	41
SD-0500401-KP	04	27		04	48		05	27
SD-0630275-SP	03	7		05	20	SS-8660810-TP	02	53
SD-0630301-SP	03	8	SS-7111260-SP	04	36		04	32
SD-0720331-SP	03	18	SS-7111310-TP	05	7	SS-8660970-TP	04	31
SD-1020701-SP	05	36	SS-7111410-SP	03	32	SS-8681950-SP	02	31
	05	32	SS-7120910-SP	03	10	SS-9151220-SR	07	17
SK-3030101-SE	06	8	SS-7151120-SP	02	39	SS-9151540-SR	07	12
SM-7030101-SE	06	10		04	45	SS-9182010-SN	07	22
SM-9061003-SE	07	28	SS-7681650-TP	02	32	SS-9661120-CP	02	30
SQ-1110402-MZ	06	27	SS-7820750-SP	04	17	V3424-552-000	07	16
SS-2110920-TP	01	43	SS-8090670-SP	01	30	V3425-552-000	07	15
SS-2110930-SP	02	45	SS-8110410-TP	03	47	WF-0740516-SF	03	12
SS-4080620-TP	05	2	SS-8110510-SP	01	22	WZ-0541510-KP	04	28
						WZ-1052010-KP	04	33

# Consolidated Sewing Machine Corp.

Website: [www.consew.com](http://www.consew.com)

## MAIN office

131 W. 25th Street  
New York, NY 10001  
Tel: 212-741-7788  
Fax: 212-741-7787  
e-mail: [consew@att.net](mailto:consew@att.net)

## Miami, FL

4013 N.W. 79th Avenue  
Miami, FL 33166  
Tel: 305-471-0200  
Fax: 305-471-0243  
e-mail: [miamisales@consew.com](mailto:miamisales@consew.com)

## Los Angeles, CA

2320 South Hill Street  
Los Angeles, CA 90007  
Tel: 213-745-8844  
Fax: 213-745-8855  
e-mail: [lasales@consew.com](mailto:lasales@consew.com)